

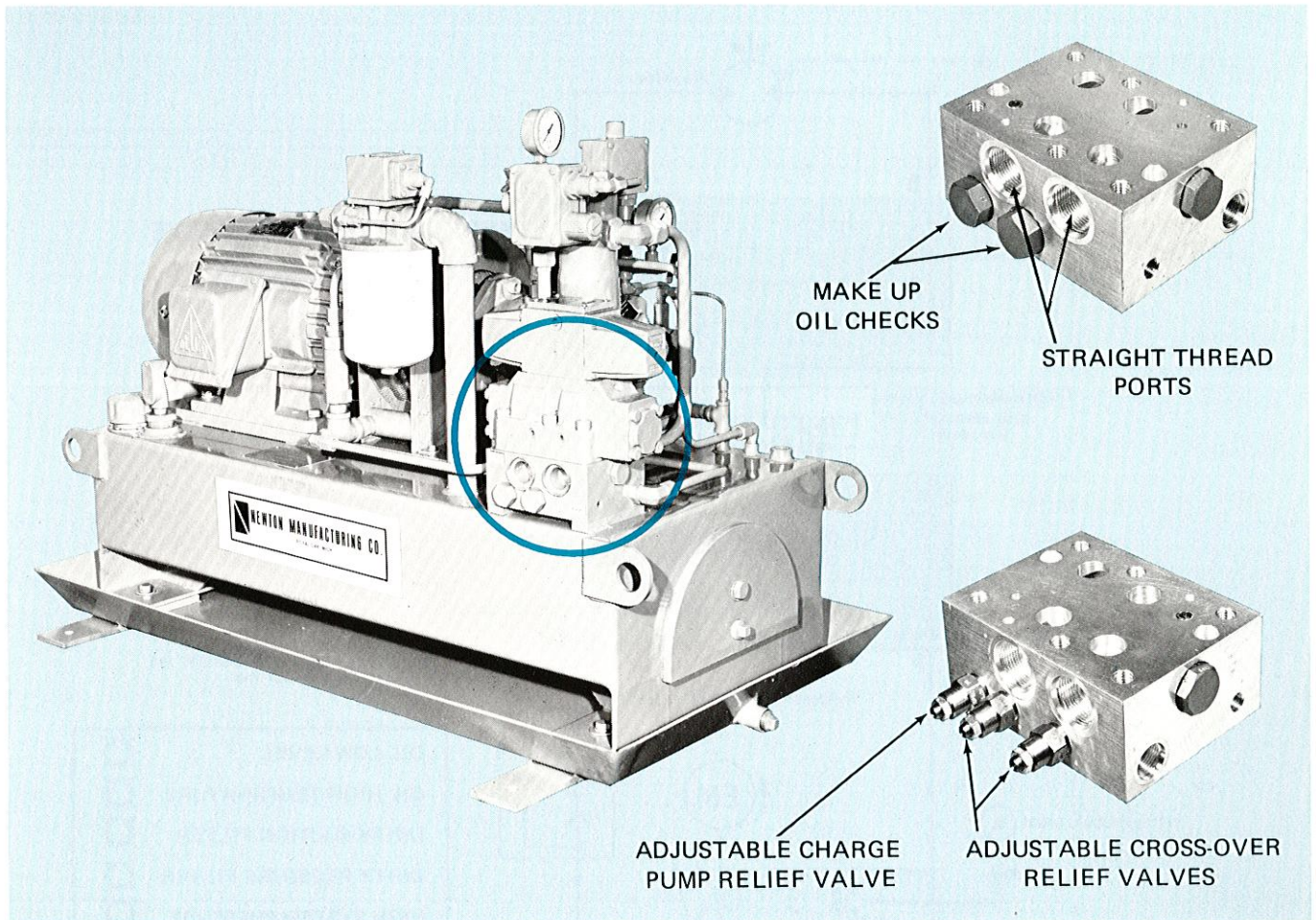

NEWTON



MODEL YRGF-LAN-AM HYDROSTATIC VALVE

FEATURES IN ONE PACKAGE:

ADJUSTABLE CROSS-OVER RELIEF VALVES -- protect the system piping and hydraulic motor from high pressure shocks.

ANTI CAVITATION -- protects the hydraulic motor from cavitation.

SHUTTLE VALVE -- allows maximum amount of system oil to be removed from closed loop for filtration and cooling.

ADJUSTABLE CHARGE PUMP RELIEF VALVE -- allows ease of adjustment in contrast to fixed relief on charge pump.

STANDARD NFPA D-06 SUBPLATE -- eliminates extra piping and has straight thread inlet and outlet ports to eliminate leakage.

RELIEF VALVES -- pilot operated balanced spools give accurate pressure regulation.

CARTRIDGE DESIGN VALVES -- assure ease of maintenance or replacement without disturbing piping.

COMPACT -- body size 5" x 6½" x 3" -- overall size 7-1/16" x 7-1/2" x 3"



NEWTON MANUFACTURING CO.

4249 DELEMERE BLVD. • ROYAL OAK, MICH. 48073 • (313) 549-9600

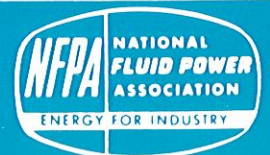



NEWTON

TYPICAL HYDROSTATIC DRIVE CIRCUIT

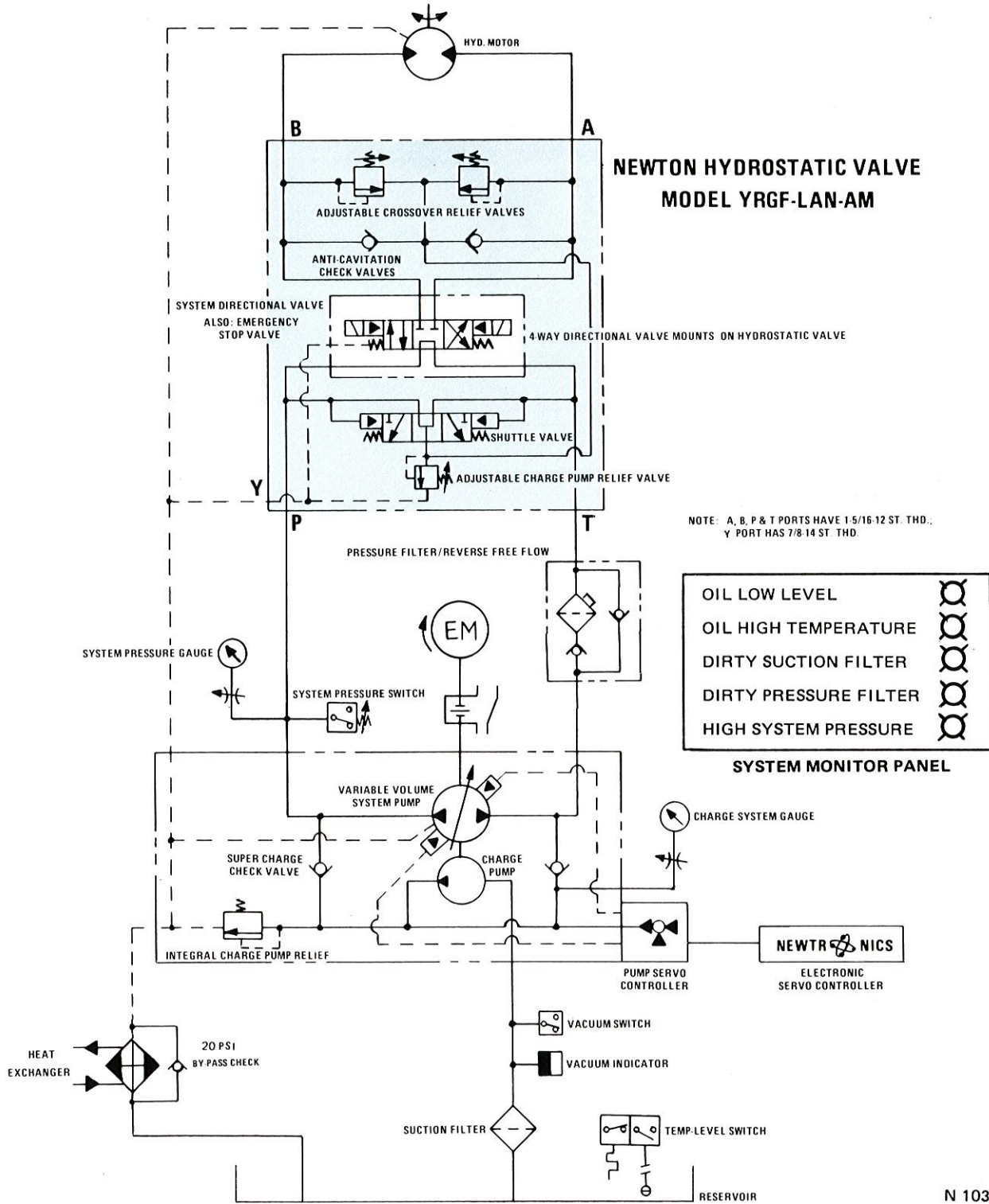

N 1035-A